

Quantum Noise as an Entanglement Meter

Leonid Levitov

MIT and KITP UCSB

Landau memorial conference
Chernogolovka, 06/22/2008

Part I: Quantum Noise as an Entanglement Meter

with Israel Klich (2008); arXiv: 0804.1377

Part II: Coherent Particle Transfer in an On-Demand Single-Electron Source

with Jonathan Keeling and Andrei Shytov (2008)
arXiv: 0804.4281



Israel Klich
UCSB



Andrei Shytov
Utah



Jonathan Keeling
Cambridge Univ.

Density matrix

Pure state vs. mixed state

$$|\Psi\rangle = \sum_i a_i |\psi_i\rangle.$$

$$E(B) = \sum_{i,j} a_i^* a_j \langle i|B|j\rangle.$$

Density matrix
Landau 1927

$$\rho = \sum_j p_j |\psi_j\rangle \langle \psi_j|,$$

$$E(B) = \text{Tr}(\rho B).$$

Quantum-statistical entropy
von Neumann 1927

$$S(\rho) = -\text{Tr}(\rho \ln \rho),$$

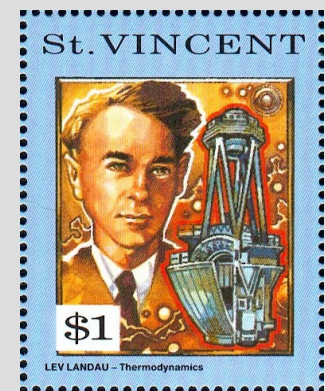
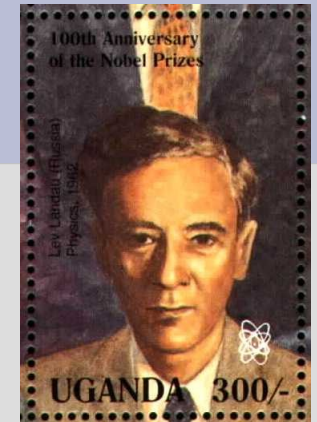
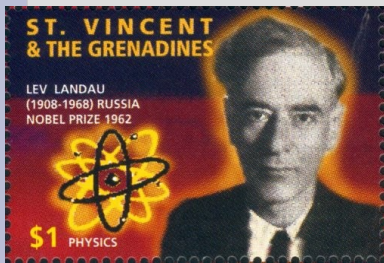

Entanglement Entropy

- Expresses complexity of a quantum state
- Describes correlations between two parts of a many-body system
- Useful in: field theory, black holes, quantum quenches, phase transitions, quantum information, numerical studies of strongly correlated systems

$$S = -\text{Tr} \rho_A \log \rho_A$$
$$\rho_A = \text{Tr}_B \rho, \quad V=A+B$$

B

A

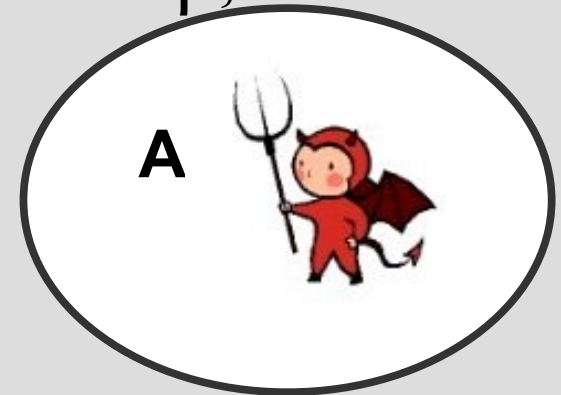

Wilczek, Bekenstein,
Vidal, Kitaev, Preskill,
Cardy, Bravyi,
Hastings, Verstraete,
Klich, Fazio, Levin,
Wen, Fradkin...

Can it be measured?

arXiv: 0804.1377

- Relate to the electron transport
- Quantum point contact (QPC) with transmission tunable in time
- Open and close “door” between reservoirs R, L, let particles from R & L mix
- Statistics of current fluctuations encode S!

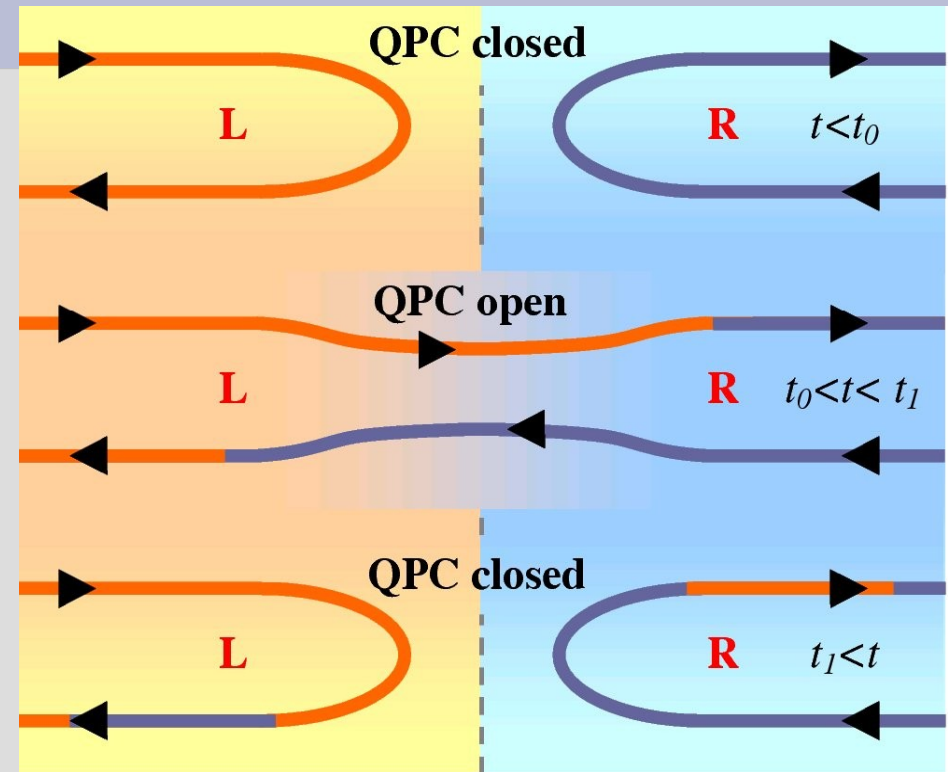

$$S_L = -\text{Tr}_L (\rho_L(t) \log \rho_L(t))$$

$$\rho_L(t) = \text{Tr}_R (\mathbf{U}(t) \rho(t=0) \mathbf{U}^\dagger(t))$$

Current fluctuations, counting statistics

- Probability distribution of transmitted charge
- Recently measured up to 5th moment in tunnel junctions, quantum dots and QPC (Reulet, Prober, Reznikov, Fujisawa, Ensslin)
- Well understood theoretically

Generating
function

Probabilities

Cumulants

$$\chi(\lambda) = \sum_n P_n e^{i\lambda n} = \exp \left(\sum_m \frac{(i\lambda)^m C_m}{m!} \right)$$

A universal relation between noise and entanglement entropy

Electron noise cumulants

$$S = \sum_{m>0} \frac{\alpha_m}{m!} C_m, \quad \alpha_m = \begin{cases} (2\pi)^m |B_m|, & m \text{ even} \\ 0, & m \text{ odd} \end{cases}$$

B_m are Bernoulli numbers ($B_2 = \frac{1}{6}$, $B_4 = -\frac{1}{30}$, $B_6 = \frac{1}{42} \dots$)

$$S = \frac{\pi^2}{3} C_2 + \frac{\pi^4}{15} C_4 + \frac{2\pi^6}{945} C_6 + \dots$$

True for arbitrary protocol of QPC driving

For free fermions Full Counting Statistics accounts for ALL correlations relevant for the entanglement entropy

Example: abrupt on/off switching

- Counting statistics computed explicitly
- Only C_2 is nonzero
- Logarithmic charge fluctuations, logarithmic entropy
- Agrees with field-theoretic calculations
- Can use electric noise to measure central charge

$$S_L = \frac{1}{3} \log \frac{t}{\tau} \quad S = \frac{c + \bar{c}}{6} \log \frac{\ell}{a} \quad \ell = v_F t.$$

Heuristically, number fluctuations in a time-dependent interval:



Space-time duality: use time window (door open/close) instead of space interval at a fixed time

Possible Experimental Realization

- Periodic switching: particle fluctuations and entropy proportional to total time;
- Fixed increment ΔS per driving period;
- DC shot noise reproduces ΔS :

$$S_2 = \frac{e^2 \nu}{\pi^2} \log \frac{\sin \pi \nu w}{\pi \nu T}$$

For $\nu=500$ MHz, $T_{\text{noise}}=25$ mK

Total # of periods

$$C_2(N) \approx \frac{N}{\pi^2} \log \frac{\sin \pi \nu w}{\pi \nu T}, \quad \nu = 1/T$$

$$C_2 \propto N \quad dS/dt = \frac{1}{3} \nu \log \frac{\sin \pi \nu w}{\pi \nu T}$$

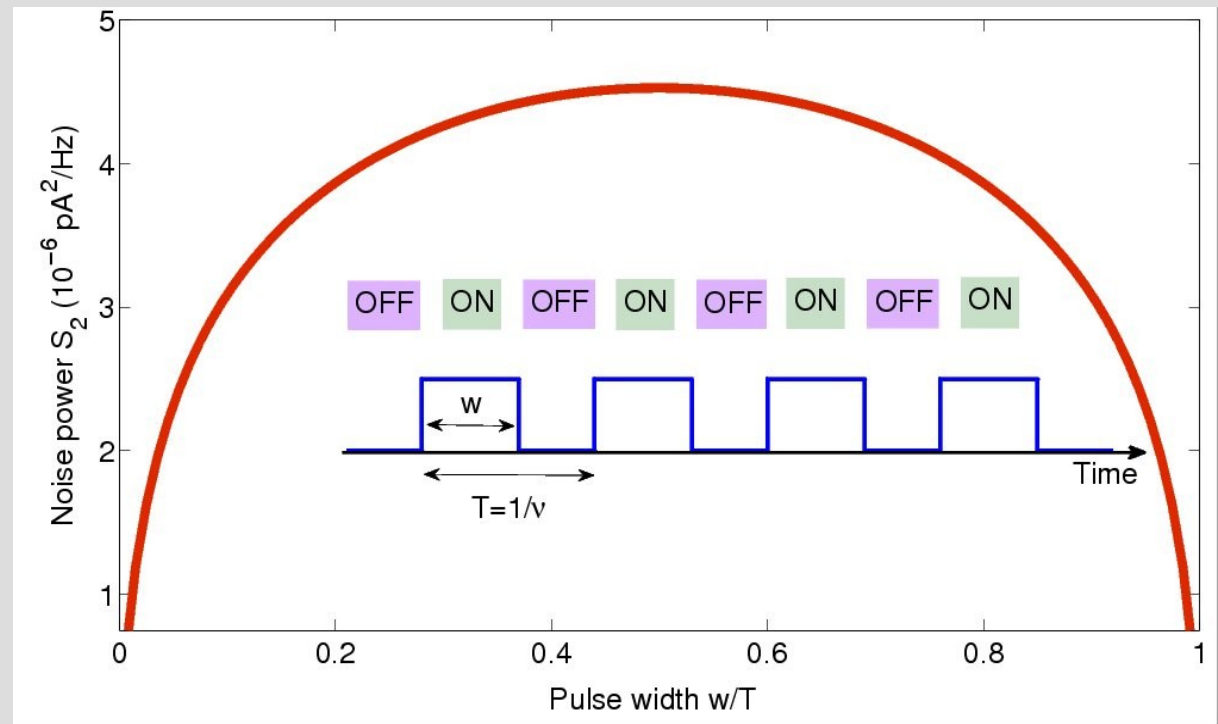

Step 1: Relate many-body and one-particle quantities

Projected density matrix (gaussian for thermal state):

$$\begin{aligned} T=0 & \quad \rho_L \propto e^{-\tilde{H}_{ij} a_i^\dagger a_j} \\ \text{or} & \\ T>0 & \quad M_{ij} = \text{Tr}_L \rho_L a_i^\dagger a_j \quad \tilde{H} = \log((I - M)M^{-1}) \\ & \quad i, j \in L, \end{aligned}$$

Find the entropy of an evolved state:

$$\begin{aligned} S_L &= -\text{Tr} (M \log M + (1 - M) \log(1 - M)) \\ S_L &= -\int_0^1 dz \mu(z) (z \log z + (1 - z) \log(1 - z)) \\ \mu(z) &= -\frac{1}{\pi} \text{Im} \text{Tr} \frac{1}{z - M + i0} = -\frac{1}{\pi} \partial_z \text{Im} \log \det(z - M + i0) \end{aligned}$$

Step 2: Counting statistics yields same quantity M

Functional determinant in an original form (LL, Lesovik '92)

$$\chi(\lambda) = \det \left(1 - n_\epsilon + n_\epsilon U^\dagger e^{i\lambda P_L} U e^{-i\lambda P_L} \right)$$

Scattering operator

Recently: Ivanov, Abanov, Nazarov, Vanevic, Belzig

$$\chi(\lambda) = \det \left((1 - M + M e^{i\lambda P_L}) e^{-i\lambda n P_L} \right)$$

$$g(z) = \log \det(1 - M + M e^{i\lambda P_L})$$

$$z^{-1} = 1 - e^{i\lambda}$$

$$g(z) = \log \det(z - M) - \text{rank}(M) \log z$$

The quantity M

- Matrix in the single-particle Hilbert space;
- Describes partition of the modes between A and B: either statistical or dynamical;
- Intrinsic to the Full Counting Statistics
- Provides spectral representation for the entropy

Step 3: Combine results 1 and 2

$$\mu(z) = \frac{1}{\pi} \text{Im} \partial_z g(z) + \text{rank}(M) \delta(z)$$

$$\log \chi = \sum \frac{(i\lambda)^m}{m!} C_m$$

$$\mu(z) = \frac{1}{\pi} \sum_m \frac{C_m}{m!} \text{Im} \partial_z \left(i\pi + \log \frac{1-z}{z} \right)^m + \text{rank}(M) \delta(z)$$

Entanglement
entropy

$$\mathcal{S} = \sum_{m=1}^{\infty} \frac{1}{m!} C_m \alpha_m$$

Noise cumulants

Relation of α_m to
Bernoulli numbers:

$$\int_0^{\infty} \frac{u^{2m} du}{\sinh^2 u} = \pi^{2m} |B_{2m}|$$

The spectrum of M for a non-unit QPC transmission

Dependence on the parameters of driving unchanged (up to a rescaling factor)

$$\mathcal{S} \sim \log \sin \pi \nu w$$
$$F = \mathcal{S}(D)/\mathcal{S}(1)$$

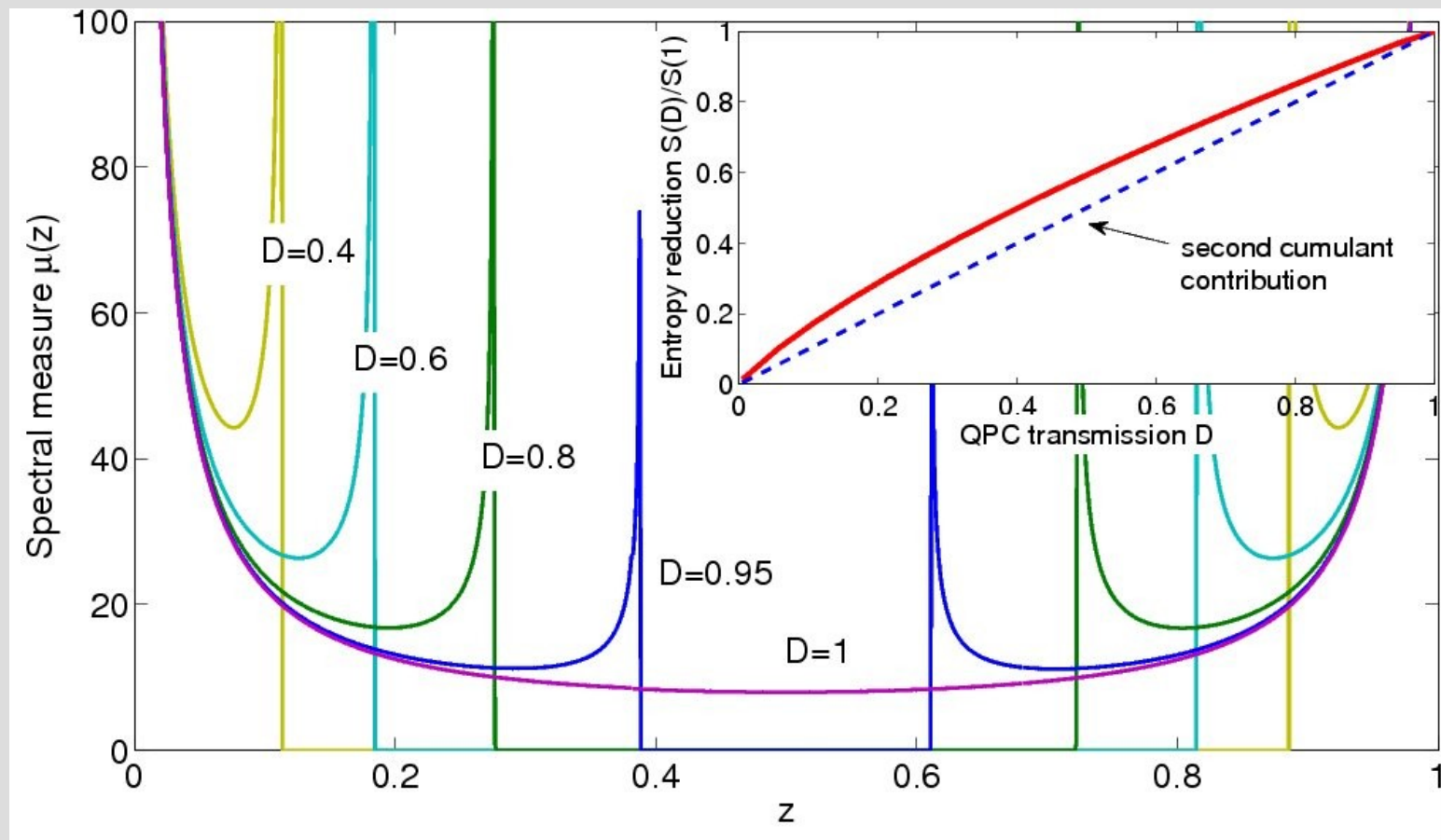

Summary & Outlook

- Universal relation between entanglement entropy and noise
- A new interpretation of Full Counting Statistics
- Generalization to other entropies (Renyi, etc);
- Opens way to measure S by electric transport (by pulsing QPC through on/off cycle)

- *Realize in cold atoms: particle number statistics*
- *Restricted vs. unrestricted entanglement*
- *Interacting systems? Neutral modes?*
- *A similar relation of entropy and noise (FCS) for Luttinger liquid is found*



?

Part II

Coherent Particle Transfer in an On-Demand Single-Electron Source

with Jonathan Keeling and Andrei Shytov (2008)
arXiv: 0804.4281

Noiseless particle source

- Transfer a particle from a localized state to a continuum without creating other excitations
- Populate a one-particle state in a Fermi gas without perturbing the rest of the Fermi sea
- Minimally entangled states in electron systems: coherent, noiseless current pulses
- Extend notion of quantized electron states (quantum dots, turnstiles) to states that can travel at a high Fermi velocity
- Bosons? Luttinger liquids?

Eject a localized electron into a Fermi continuum in a noiseless fashion

Electron system:

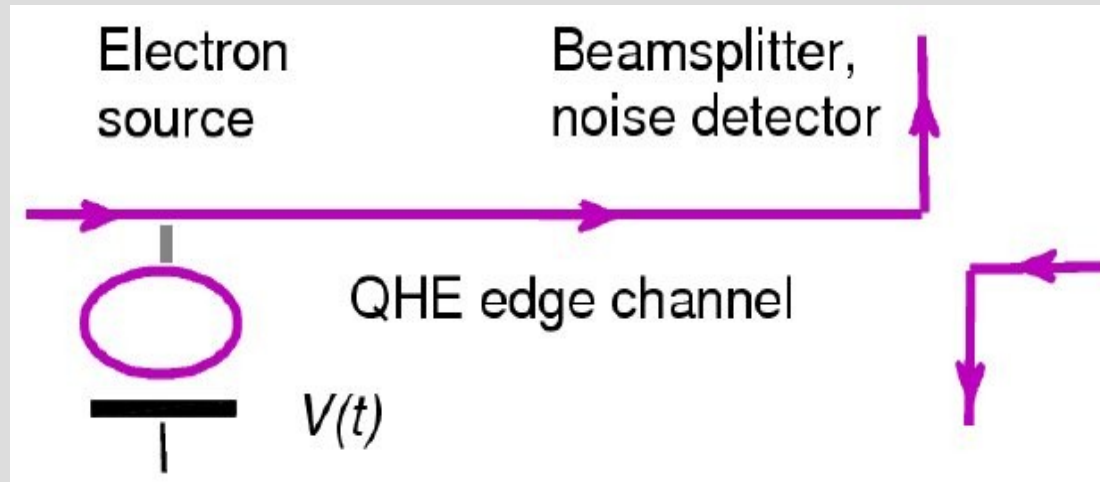

Cold atoms:

Quantum Tweezers (one-atom optical trap in a quantum gas)

Too noisy?

Experimental realization in a 1d QHE-edge electron system

Quantized current pulses in an On-Demand Coherent Single-Electron Source

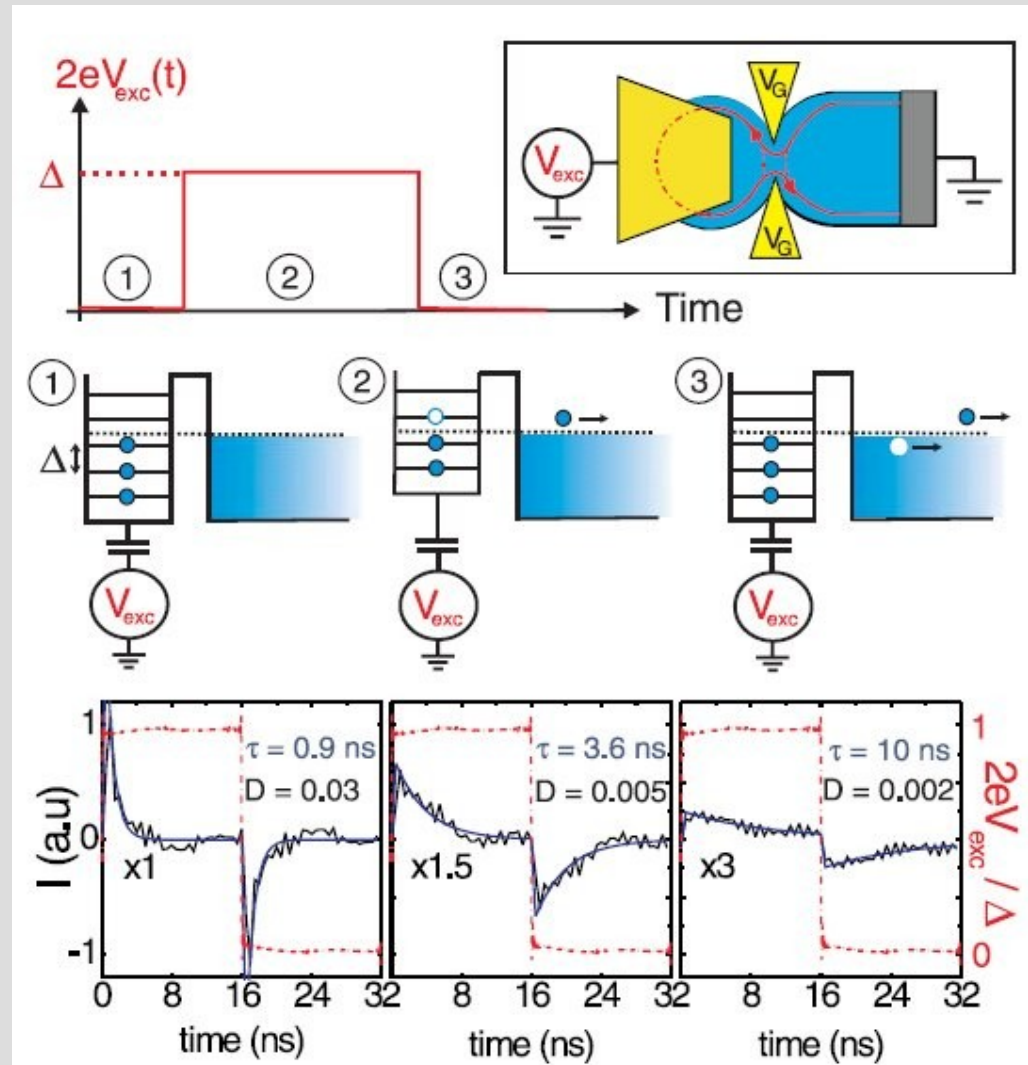

G. Fève et al.
Science 316, 1169
(2007)

Excitation content: particles and holes

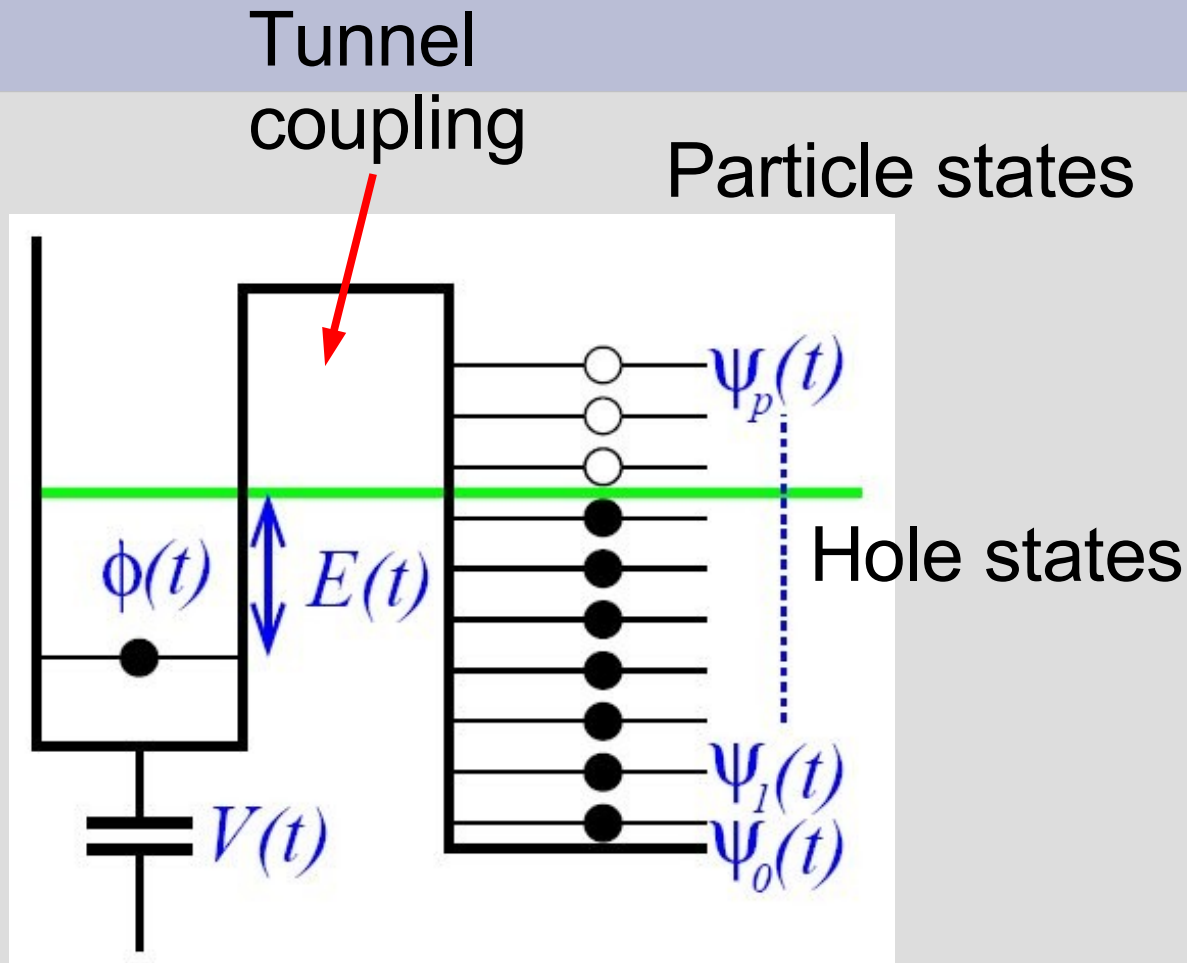

No splash, Captain?

The number of excitations: **unhappiness** = $N_p + N_h$

Minimize unhappiness?

Optimize driving so that

$$N_{\text{ex}} = N_e + N_h = \mathbf{min}, \quad \Delta N = N_e - N_h = 1$$

Localized and delocalized particles
indistinguishable: Excitation unavoidable? No.

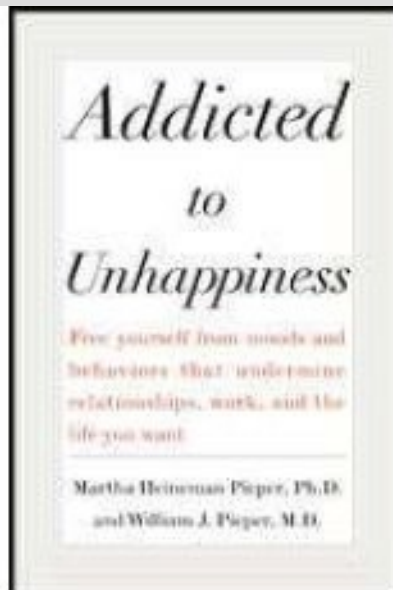

Multilevel Landau-Zener problems, exact S-matrix

Demkov-Osherov

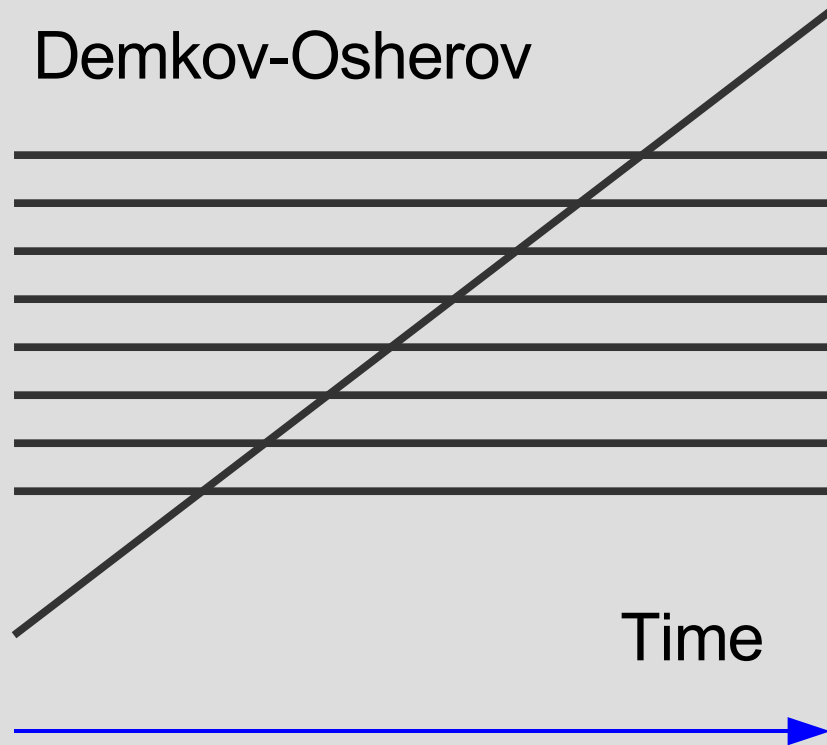

Discrete states,
linear driving

Our problem:
Continuous spectrum,
arbitrary driving

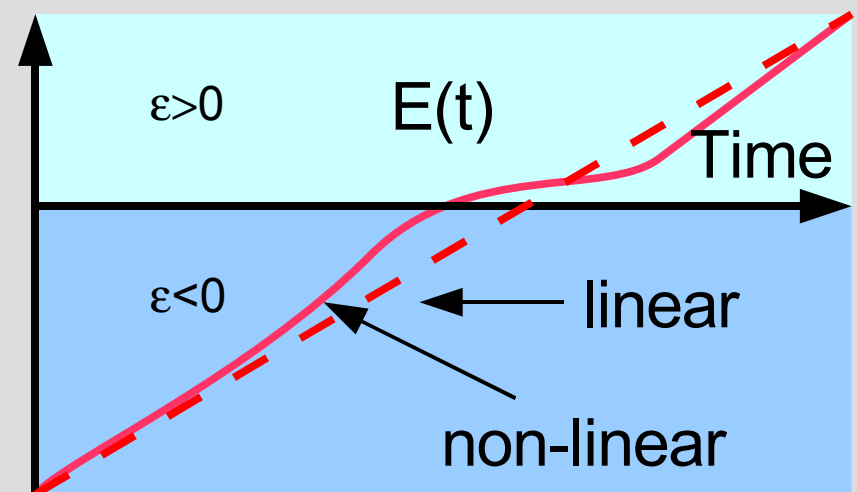

Time-dependent S-matrix

Gate voltage, tunnel coupling

$$[i\partial_t - E(t)] \phi(t) = \sum_p \lambda(t) \psi_p(t),$$

$$[i\partial_t - \epsilon_p] \psi_p(t) = \lambda^*(t) \phi(t),$$

Quasi 1D scattering channel representation:

In-state:

$$\psi(t, x) = \sum_p e^{ipx} \psi_p(t) \quad \epsilon_p \rightarrow -iv_F \partial_x.$$

$$[i\partial_t - E(t)] \phi(t) = \lambda(t) \int dx \delta(x) \psi(t, x)$$

$$[i\partial_t + iv_F \partial_x] \psi(t, x) = \lambda^*(t) \delta(x) \phi(t)$$

$$\psi(t, x < 0) = \psi_0(t, x) = \frac{1}{\sqrt{2\pi}} e^{-i\epsilon'(t-x/v_F)}$$

The S-matrix:

Out-state:

$$U(\epsilon, \epsilon') = \int \frac{dt}{\sqrt{2\pi}} \psi(t, x > 0) \exp \left[i\epsilon \left(t - \frac{x}{v_F} \right) \right]$$

Find the S-matrix:

$$\psi(t, x) = \psi_0 \left[t - \frac{x}{v_F} \right] - \frac{i}{v_F} \lambda^* \left[t - \frac{x}{v_F} \right] \phi \left[t - \frac{x}{v_F} \right] \theta(x).$$

$$\left[i\partial_t - E(t) + i\frac{|\lambda(t)|^2}{2v_F} \right] \phi(t) = \lambda(t)\psi_0(t)$$

Resonance width:

$$\phi(t) = -i \int_{-\infty}^t dt' \lambda(t') \psi_0(t') e^{X(t,t')} \quad |\lambda(t)|^2/v = \Gamma(t)$$

$$i\partial_t X(t, t') = [E(t) - i\Gamma(t)/2] X(t, t')$$

ANSWER:

$$U(\epsilon, \epsilon') = \delta(\epsilon - \epsilon') - \int_{-\infty}^{\infty} dt \int_{-\infty}^t dt' \frac{\lambda(t)\lambda(t')}{2\pi v_F} e^{A(t,t')}$$

$$A(t, t') = i(\epsilon t - \epsilon' t') - \int_{t'}^t d\tau \left[\frac{\Gamma(\tau)}{2} + iE(\tau) \right]$$

Number of excitations

Energy representation:

$$N^+ = \langle \Omega | U^\dagger \sum_{\epsilon > \epsilon_F} a_\epsilon^\dagger a_\epsilon U | \Omega \rangle = \int_{\epsilon_F}^{\infty} d\epsilon \int_{-\infty}^{\epsilon_F} d\epsilon' |U(\epsilon, \epsilon')|^2$$

Time representation:

$$N^+ = - \left(\frac{\Gamma}{2\pi} \right)^2 \int_{-\infty}^{\infty} dt \int_{-\infty}^t dt' \int_{-\infty}^{\infty} ds \int_{-\infty}^s ds' \frac{\exp \left[-\frac{\Gamma}{2} (t - t' + s - s') - i \int_{t'}^t E(\tau) d\tau + i \int_{s'}^s E(\tau) d\tau \right]}{(t - s + i0)(t' - s' + i0)}$$

Excitation number depends on the protocol, $E(t)$

Optimal driving?

Linear driving minimizes unhappiness

$$E(t) = ct,$$

rapidity



Slow or fast rapidity, degeneracy in c

Resulting state depends on c value

Relevant energy window: $|\varepsilon - \varepsilon_F|$ of order Γ

S-matrix for linear driving

$$A(T, \tau) = i(\epsilon + \epsilon')\frac{\tau}{2} - i(\epsilon' - \epsilon)T - \frac{\Gamma}{2}\tau - icT\tau.$$

$$t = T + \tau/2, \quad t' = T - \tau/2, \quad \text{with } \tau > 0$$

S-matrix: rank-one particle/hole block

$$U(\epsilon \neq \epsilon') = \theta(\epsilon - \epsilon')\frac{\Gamma}{c}e^{-\frac{\Gamma}{2c}(\epsilon - \epsilon') + \frac{i}{2c}(\epsilon^2 - \epsilon'^2)}.$$

$$N^+ = 1 \quad N^- = 0 \quad N^+ - N^- = 1$$

No e/h pairs: $U_{ab} U_{a'b'} - U_{ab'} U_{a'b} = 0$

Current pulse profile at different rapidities

$$\psi(t, x) = \sqrt{\frac{\Gamma}{c}} \int_0^\infty \frac{d\epsilon}{\sqrt{2\pi}} \exp \left[-i\epsilon \left(t - \frac{x}{v_F} \right) - \frac{\Gamma\epsilon}{2c} + i\frac{\epsilon^2}{2c} \right]$$

High c :
exponential
profile

One-electron pulse
with fringes on the
trailing side

Low c :
Lorentzian
profile

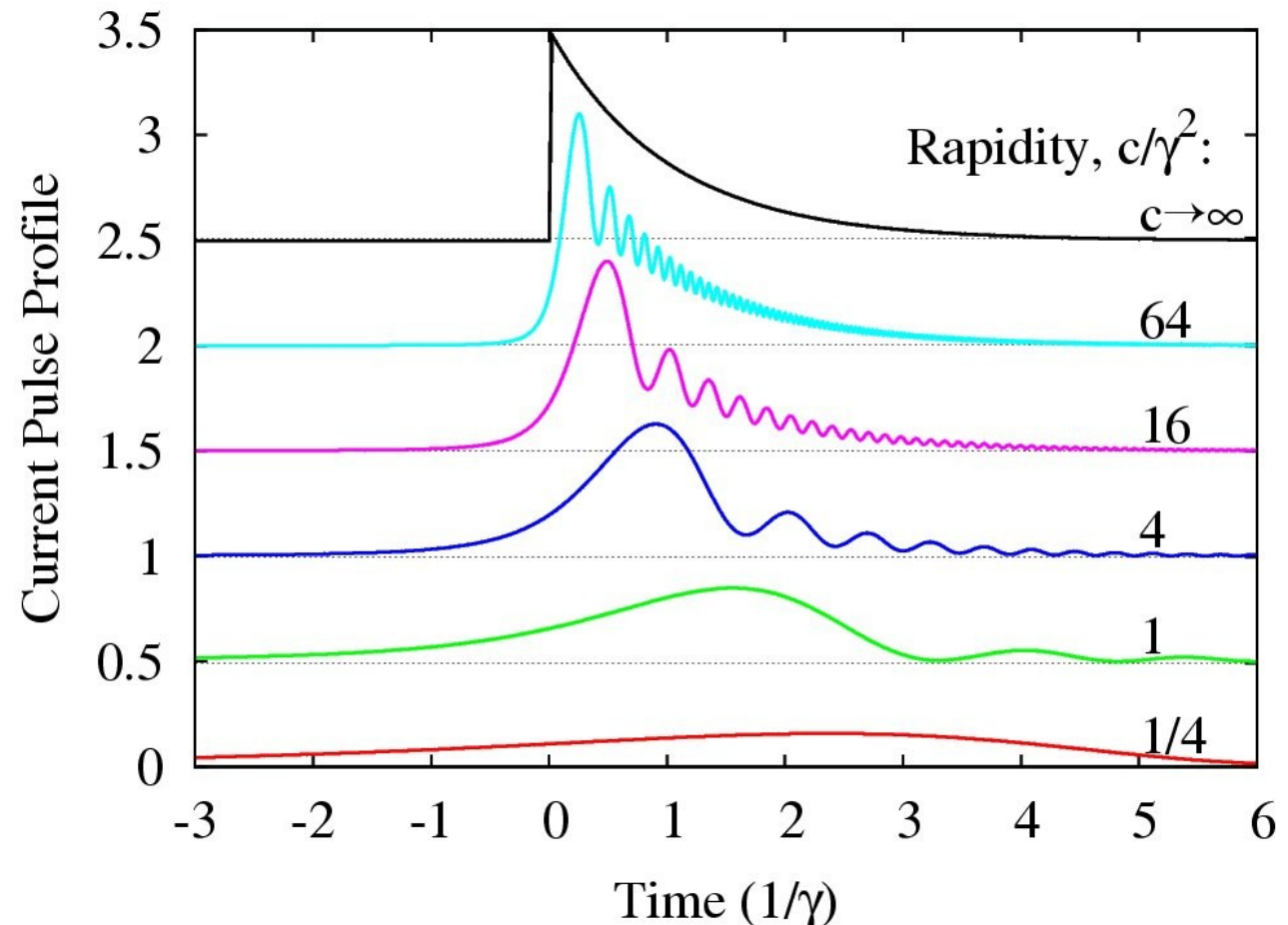

Energy excitation and e/h pair
production suppressed by Fermi
statistics

Pauli principle helps to eliminate
entanglement

Use noise to measure unhappiness

- Send current pulses on a QPC (beamsplitter):
The partition noise generated at QPC is a direct measure of the excitation number
- Use a periodic train of pulses, vary frequency, protocol, duty cycle, etc, to demonstrate noise minimum
- At finite temperature must have $h\nu > kT$:
e.g. $T = 10 \text{ mK}$, $\nu > 200 \text{ MHz}$

More examples

- Harmonic driving, $E(t)=E_0+\cos\Omega t$, simulates repeated linear driving;
- Linear driving + classical noise:

$$E(t) = ct + \delta V(t),$$
$$\langle \delta V(t)\delta V(t') \rangle = \gamma_2 \delta(t-t')$$

Total number of excitations:

$N_{\text{ex}} = 1$ for fast driving;

$$N^{\text{ex}} \approx \frac{2\gamma\gamma_2}{\pi c} \ln \frac{\omega_0}{\gamma_*}$$

for slow driving (multiple crossings of the Fermi level);

Crossover at $c \sim \gamma\gamma_2$

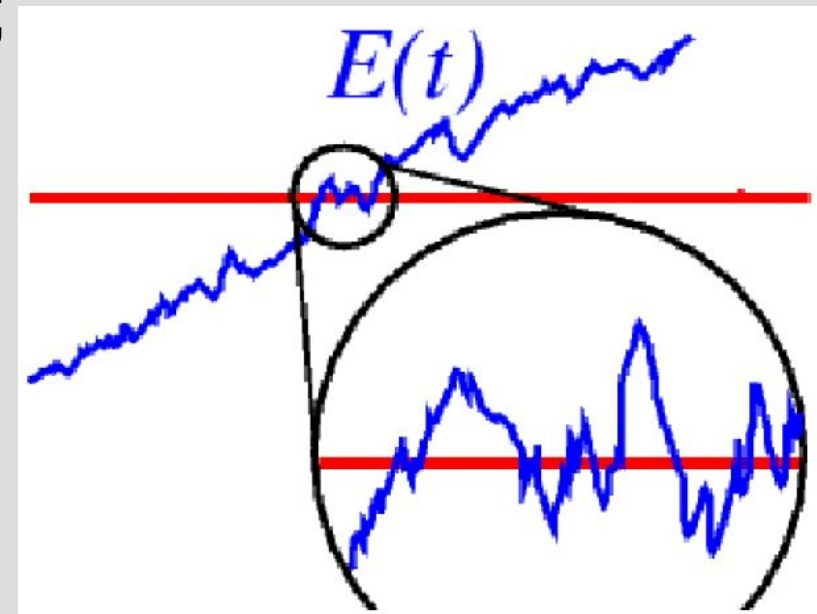

Slow driving

A more intuitive picture at slow driving:
quasistationary time-dependent scattering phase

$$\theta(t) = \arctan((\varepsilon - E(t))/\Gamma)$$

Translates into an effective time-dependent ac voltage:

$$V(t) = (h/e) d\theta/dt$$

Noiseless excitation realized for Lorentzian pulses
of quantized area (PRL 97, 116403 (2006))

Clean excitation by a voltage pulse

- Particle excited above E_F ;
- Other particles filling the void at $E < E_F$ (near $+k_F$);
- Undisturbed Fermi sea (no mess left behind);
- Counter-propagating hole (similar, near $-k_F$).

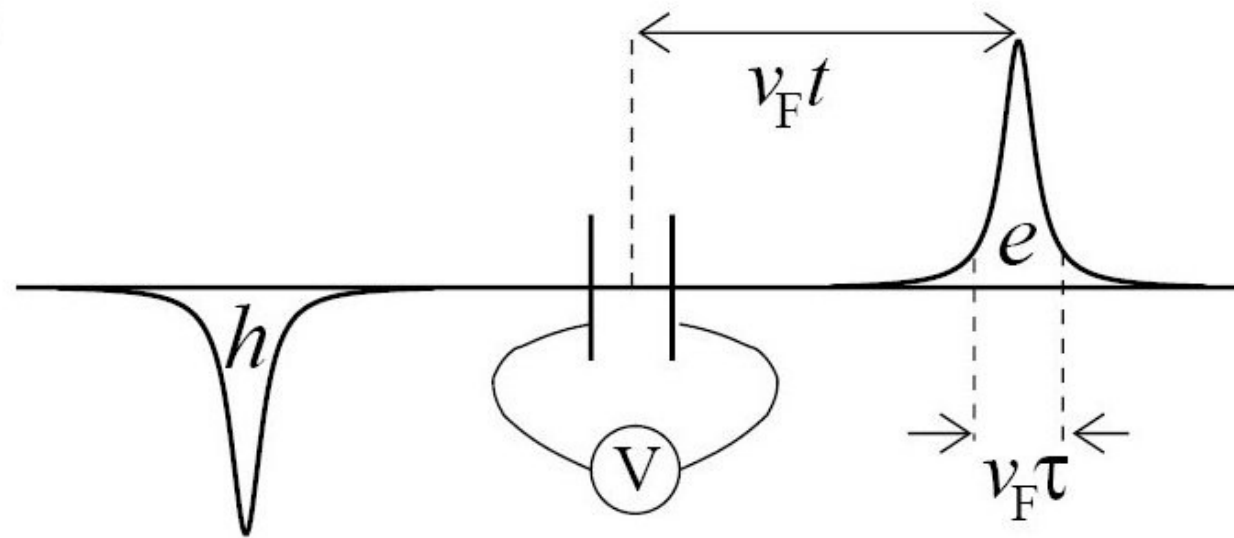
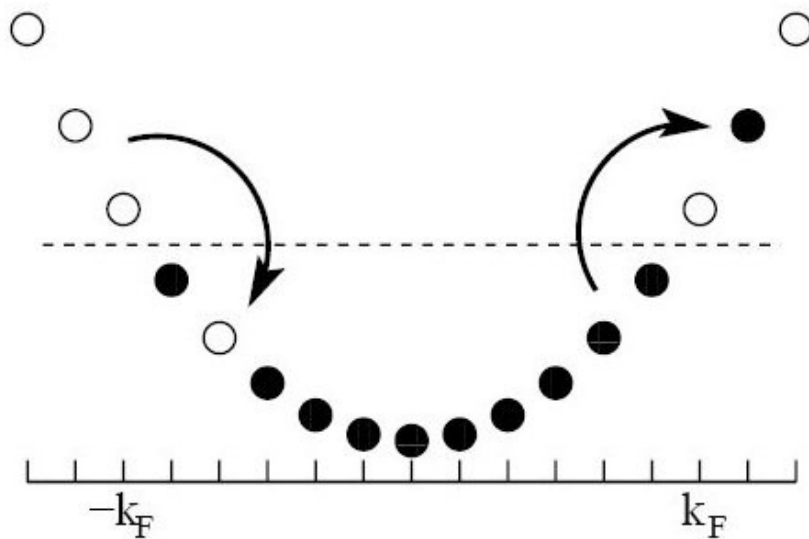

Minimal noise requirement

$$N_{ex} = N_e + N_h \rightarrow \min, \quad \Delta q/e = N_e - N_h = n = \text{const}$$

- An interesting variational problem, solved by pulses of integer area $2\pi n$:

$$V(t) = \frac{\hbar}{e} \sum_{i=1\dots n} \frac{2\tau_i}{(t - t_i)^2 + \tau_i^2} \quad (\tau_i > 0)$$

Lorentzian pulses (overlapping or non-overlapping): $N_h = 0$ or $N_e = 0$

Degeneracy: $N_{ex} = n$, the same for all t_i, τ_i

WHEN DOES A UNITARY EVOLUTION EXCITES AT MOST ONE PARTICLE?

Evolve a Fermi sea, $n = \sum_{E_k < E_F} |k\rangle\langle k|$:

$$n \rightarrow UnU^{-1}, \quad U_{+-} = (1 - n)Un, \quad U_{-+} = nU(1 - n)$$

Criterion: IF and ONLY IF $U_{-+} = 0$, $U_{+-} = c|\phi_+\rangle\langle\phi_-|$ a rank one matrix.

Proof: $\langle k'|U|k\rangle = \langle k'|\phi_+\rangle\langle\phi_-|k\rangle$ for $E_k < E_F$, $E_{k'} > E_F$;

$U_{a \rightarrow a'}U_{b \rightarrow b'} - U_{a \rightarrow b'}U_{b \rightarrow a'} = 0$, — at most one particle excited.

Transition amplitude for Lorentzian pulses $\psi(t, x) = \psi(0, x + vt)e^{i\phi(t)}$:

$$e^{i\phi(t)} = \frac{t + i\xi_k^*}{t - i\xi_k}, \quad \xi_k = \tau_k - it_k$$

Fourier transform: $\int e^{i\phi(t)+i\omega t} dt = \delta(\omega) + \sqrt{2\tau}e^{-\xi\omega}\theta(\omega)$, $\omega = E_{k'} - E_k$;
 Criterion fulfilled due to multiplicativity of exp!

FEATURES:

- A many body excitation which conspires to behave like a single particle;
- Direct product of e and h;
- Energy distribution width \hbar/τ — inverse pulse width;
- Generalized to many pulses of equal sign. “Laughlin” algebra:

$$\prod_{k=1}^n e^{i\phi_k(t)} |0\rangle = \prod_{k < k'} \frac{\xi_k + \xi_{k'}^*}{\xi_k - \xi_{k'}} A_n^\dagger A_{n-1}^\dagger \dots A_1^\dagger |0\rangle, \quad A_k^\dagger = \sum_{\epsilon > E_F} e^{-\xi_k \epsilon} a_k^\dagger$$

- Pulses of opposite sign: entangled e-h pairs and an undisturbed Fermi sea;

$$e^{-i\phi_1(t)} e^{i\phi_2(t)} |0\rangle = \frac{\xi_k - \xi_{k'}}{\xi_k + \xi_{k'}^*} A_1^\dagger B_2^\dagger |0\rangle + \frac{2\sqrt{\tau_k \tau_{k'}}}{\xi_k + \xi_{k'}^*} |0\rangle$$

- Generalized for chiral Luttinger liquid (QHE edge state):
 $e \rightarrow e_* = e/m$, $\int V dt = h/e_*$ — fractional charge pulses.

Summary

- Many-body states that conspire to behave like one-particle states
- Release/trap a particle in/from a Fermi sea in a clean, noiseless way
- Single-particle source can be realized using quantum dots: a train of quantized pulses of high frequency
- Can employ particle dynamics with high Fermi velocity 10^8 cm/s to transmit quantized states in solids