



- look up in red(white, black..) book
- hammer + swear words
- handwaving + .45
- let it pass
- throw a monkey wrench into
- ab initio DFT
- scaling
-

Landau 100, Chernogolovka, 2008



Statistics of measurements of non-commuting variables

Yuli V. Nazarov

Hongduo Wei

Kavli Institute of Nanoscience Delft

density matrix

quantum measurement: detector

proper toolset

Solid-state-based qubits

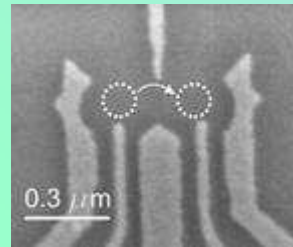
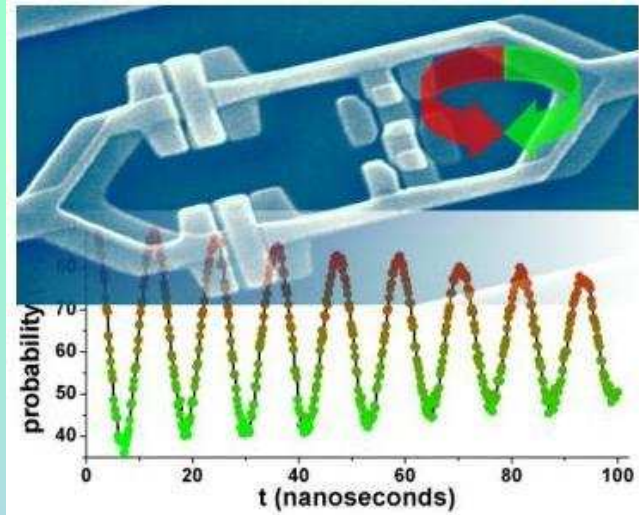

Spin
Charge
Phase
Flux

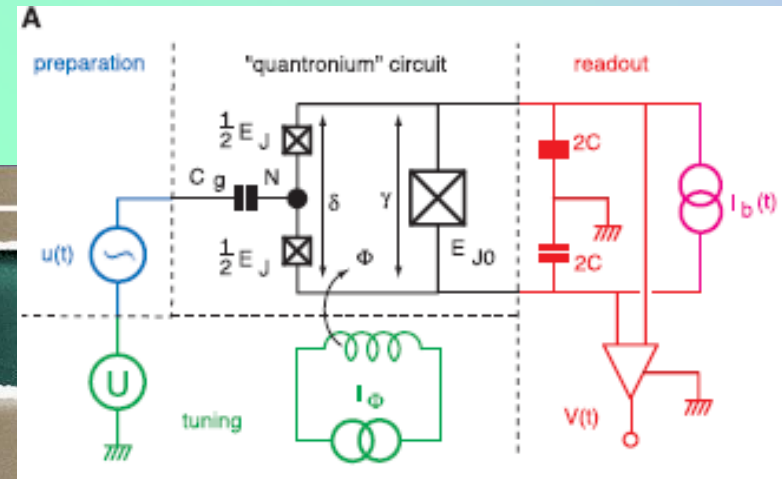
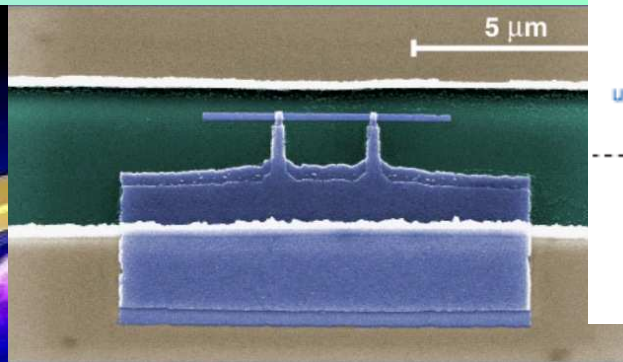

- Parts of electric circuit

Qubits + amplifiers

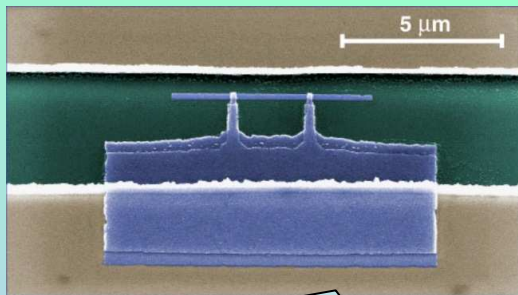

input



Feedback:
foe or friend?

output

Landau 100, Chernogolovka, 2008

Outline

- **Preliminary**
 - Misconceptions around quantum measurements
 - '99-'06 theor. Activities – linear continuous measurement
 - QND experiments on qubits
- **Past**
 - measurement = statistics
 - Theoretical engine to access statistics of realistic measurements
 - Test runs
 - Non-commuting measurement: quantum monitoring
- **Present**
 - Pumping a qubit
 - Detector with a strobe
- **Future**
 - Pumping entanglement?

D.V. Averin

M. Buttiker

A.A. Clerk

S.M. Girvin

A.N. Jordan

A.N. Korotkov

Y. Makhlin

G. Schon

A. Shnirman

A.D. Stone

Quantum measurement vs. measurement of smth. quantum

- **Quantum measurement**
 - No measurement! Information transfer
 - Projective: wave function collapses
 - Is it realistic?
- **The collapse does not matter if**
 - Particle decay
 - Scattering
 - Quantum optics
- **It matters if the quantum system persists**
 - Measurement time
 - Decoherence time
 - Relaxation time
- **QND definition: repetitive measurements give the same result**
- **Implicated: each measurement is projective**



Linear measurement

- (almost) Any measurement – linear measurement
- Any detector – linear amplifier

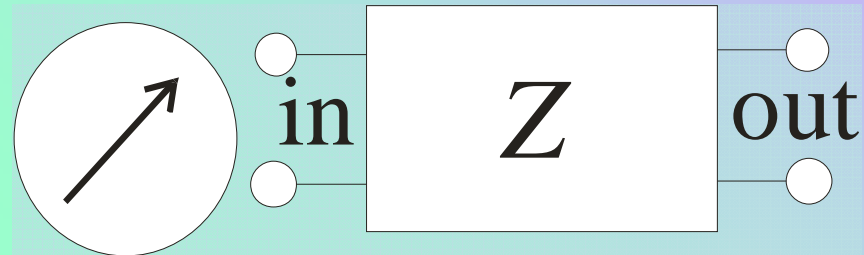

- Gain(s) $\mathbf{a}_{12}, \mathbf{a}_{21} = \mathbf{0}$, impedances (zero reverse gain condition)
- Output noise \mathbf{S}_{oo} , noise of inp.variable \mathbf{S}_{ii} noise correlations \mathbf{S}_{io}
- Quantum restrictions

$$S_{oo} S_{ii} \geq S_{oi}^2 + \hbar^2 a_{12}^2 / 4 \Rightarrow$$

dimensionless

$$C_{\square} \geq 1$$

classicity

- Acquisition rate

$$\Gamma_{ac} = \frac{a_{12}^2}{S_{oo}}$$

$$\Gamma_{\phi} = \frac{2S_{ii}}{\hbar^2} = 2C_{\square}\Gamma_{ac}$$

- NOT faster than decoherence rate

Landau 100, Chernogolovka, 2008

Quantum non-demolition measurement

- **Definition:** repetitive measurements give the same result
- **Implicated:** each measurement is projective

$$H = H_{qubit} + H_{coupling} + H_{detector}$$

- **Qubit Ham. and Coupling commute**

$$H_{qubit} = h\hat{\sigma}_z$$

$$H_{coupling} = \hat{\sigma}_z \hat{i}; \quad \hat{i} - \text{input variable}$$

- **Fluctuations of $i = \text{decoherence}$**

Landau 100, Chernogolovka, 2008

Hamiltonians (1 qu. + 1 det.)

$$H = H_{\text{qubit}} + H_{\text{coupling}} + \sum_k \hbar \omega_k \hat{b}_k^\dagger \hat{b}_k$$

$$H_{\text{qubit}} = h \hat{\sigma}_z, \quad H_{\text{coupling}} = -\hat{\sigma}_z \hat{i}.$$

$$\hat{i} = \sum_k i_k \hat{b}_k + h.c.; \quad \hat{o} = \sum_k o_k \hat{b}_k + h.c.;$$

Scrambled to :

correlators – noises

$$S_{oi}(t, t') = \langle \hat{o}(t) \hat{i}(t') \rangle$$

τ - duration of the measurement

$$\int_{t_1}^{t_1+\tau} \hat{o}(t) dt$$

To compute : Statistics of outcomes : $\hat{p} = \frac{\int_{t_1}^{t_1+\tau} \hat{o}(t) dt}{\tau}$

Features of our engine

- *Note:* any realistic measurement – the distribution of the outputs
- *Purpose:* to evaluate the distribution
- *Design:* generating function (χ) of the dist. from an extended Bloch equation for quasi-density matrix $\rho(\chi)$

$$\frac{\partial \hat{\rho}}{\partial t} = i[\hat{H}, \hat{\rho}] - i\chi[\hat{\sigma}_z, \hat{\rho}]_+ - \Gamma(\hat{\rho} - \frac{1}{2}\text{Tr}(\hat{\rho})) - \chi^2 \hat{\rho} / 2$$

- *Scalability:* many qubits, many detectors, many measurements
- *Restrictions:* white noise, no-delay feedback

Details of (quasi) density matrix

- *Normal density matrix*: in space of $\text{spin}(X)\text{outcome}(p)$ $\hat{\rho}(p_1, p_2)$
- *quasi-density matrix*: Fourier of diagonal
$$\hat{\rho}(\chi) = \int dp e^{-ip\chi} \hat{\rho}(p_1, p_2)$$
- *Godsend*: diagonal/non-diagonal decouple

QND measurement

- Confirmed
 - projective
 - repetitive
 - undoable(?)
- (Korotkov, Jordan)
- Lots of quantitative details

Ideal

Realistic

Landau 100, Che

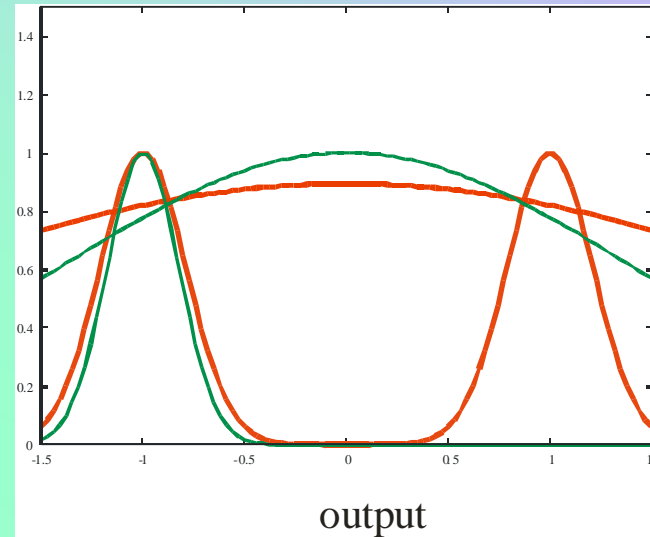

First

Second

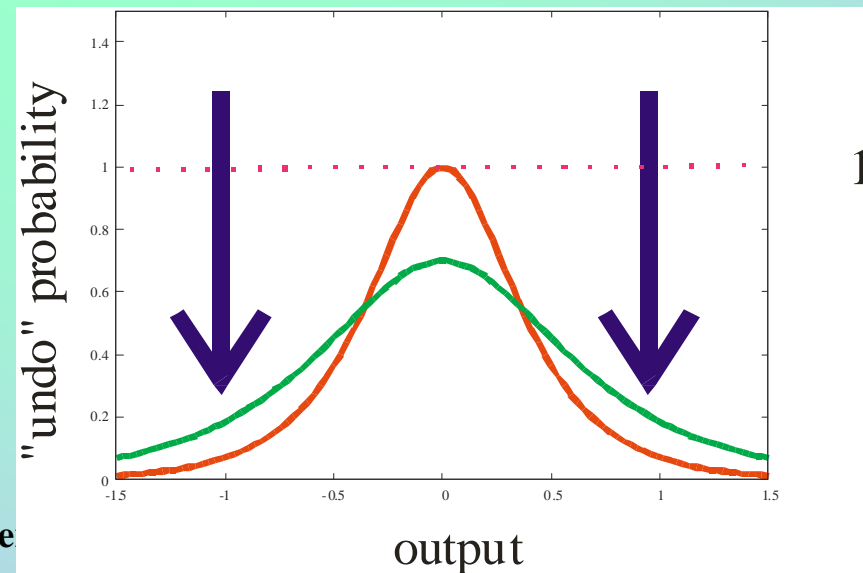

Forbidden measurement

- Quantum measurement of non-commuting variables=nonsense=forbidden
- Forbidden = not good for you
- No reason not to try

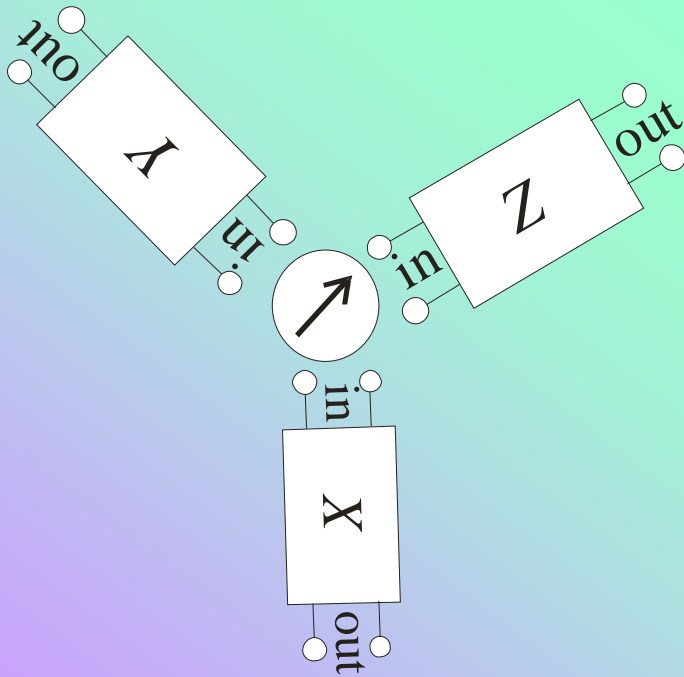

Can you guess the result?

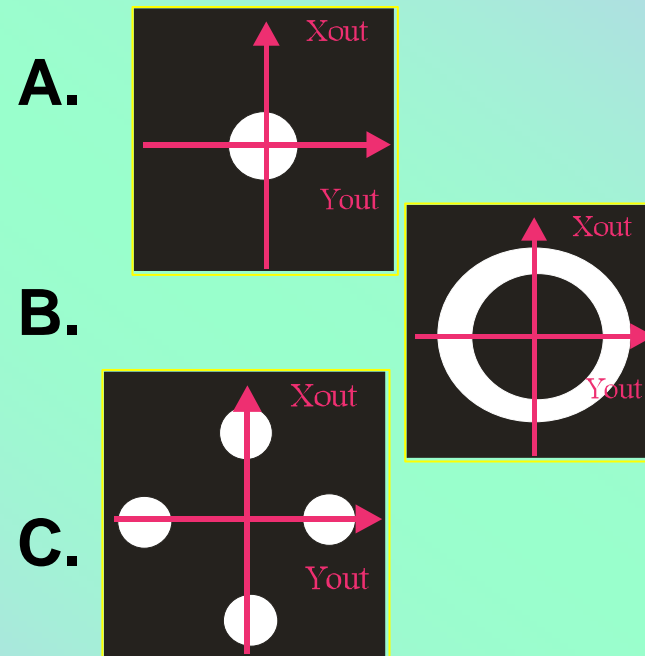

Distribution of outputs

- Spherically-symmetric
- Centered at zero
- Additional noise
- Non-gaussian shape
- Probability of large outputs enhanced

$$V = \sqrt{V_x^2 + V_y^2 + V_z^2}$$

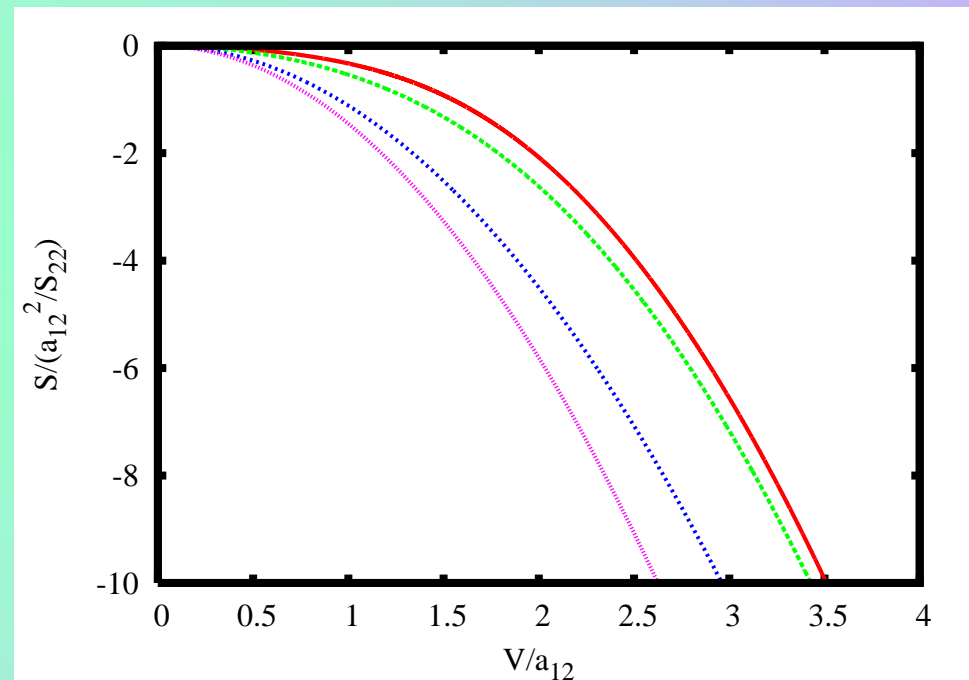

Fidelity

- After an elementary measurement
 - three outputs + qubit density matrix
- Any (cor)relation?
 - three outputs => polarization => a quantum state $|\psi\rangle$
 - how good is a match? **Fidelity:** $f = 2\langle\psi|\hat{\rho}|\psi\rangle - 1$

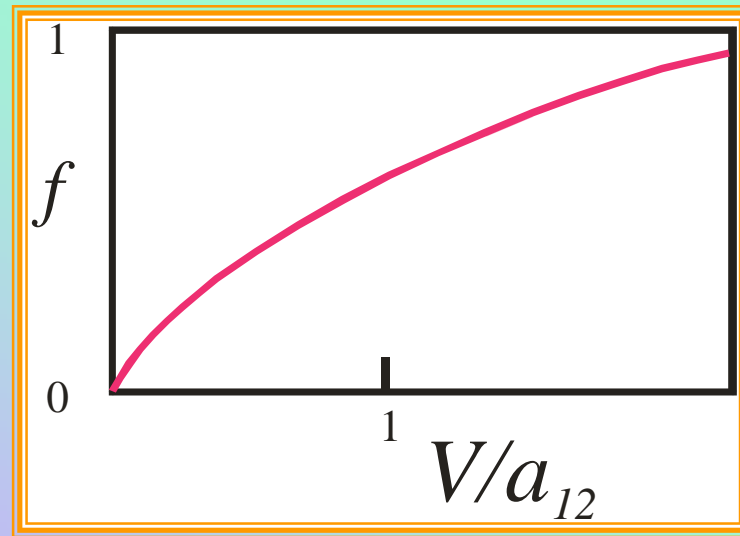

Landau 100, Chernogolovka, 2008

Ideal monitoring of the wave function

- We can know more than measure
- One-shot measurement in three directions: **impossible**
- Ideal monitoring in three directions: **possible**
- Wait for and look at big **outputs**

Datum	Measurement	Output Assesment	Action
08:00	1	typical	skip
08:01	2	typical	skip
08:02	3	Big: fidelity 90%	Write down: sz =0; sx = 0.4; sy=0.9
08:03	4	typical	skip
08:04	5	typical	skip
08:04	6	typical	skip

Fidelity and duration

- Waiting time exponentially long?
 - need numerical estimation

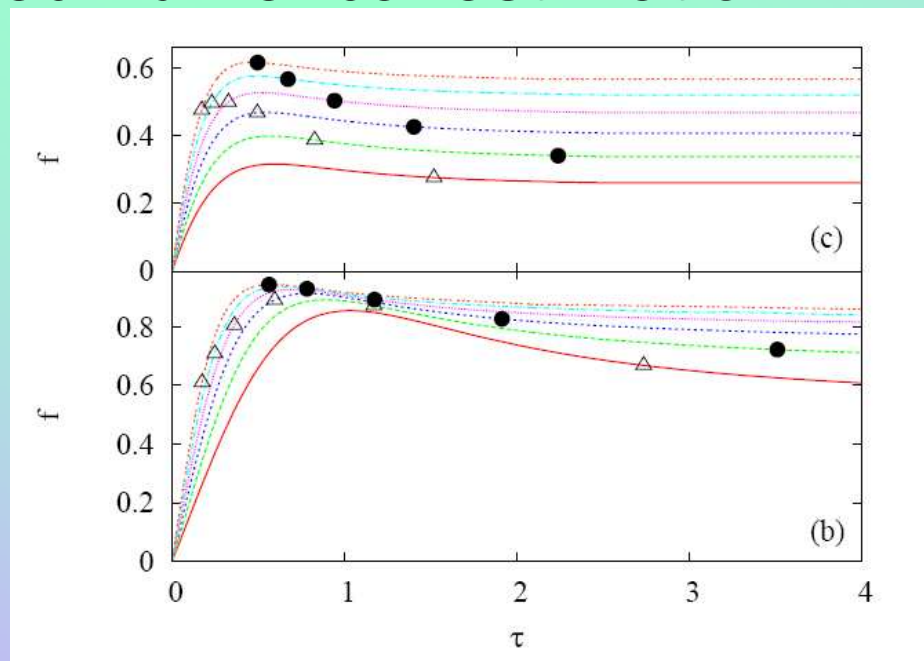

- Optimistic conclusion
 - 10 % relevant, fidelity 95 % $\Rightarrow t = 7 t_{\text{dec}}$

Relation to quantum information goodies

- Entanglement as a resource
 - distillation algorithms (Bennett, 1998)
 - purification algorithms (Nakazato, 2003)
 - quantum error correction
- Implementation?
 - not specific for photons
 - we provide one
 - more qubits, detectors, feedbacks ...

Pumping qubit: idea

- **Feedback? Feedback!**
 - get output => send to input
 - and do not listen back
- **Equilibrium-Non equilibrium**
 - listen - not listen
 - in our engine: asymmetric susceptibilities
- **Why pumping?**
 - nuclear spin pumping
- **Challenge**
 - touch x,z , polarize in y
 - improve polarization with quantum monitoring of x,z

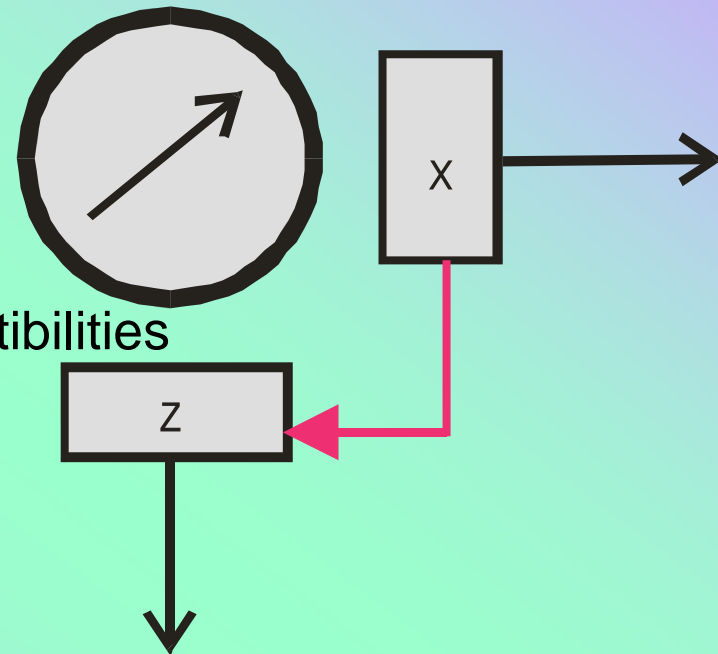

Pumping qubit: results

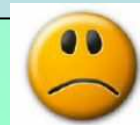
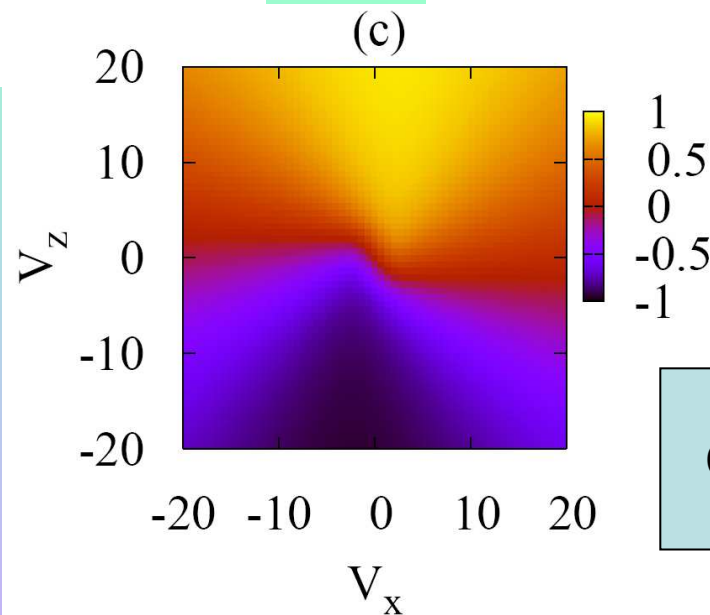
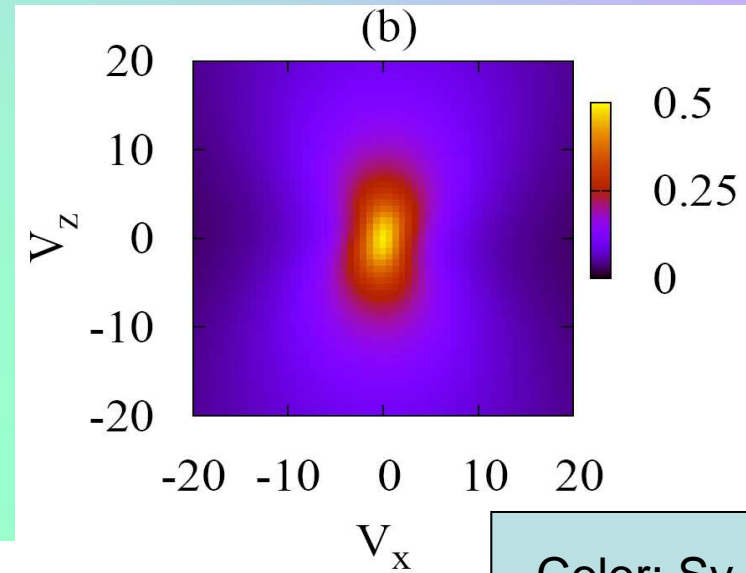
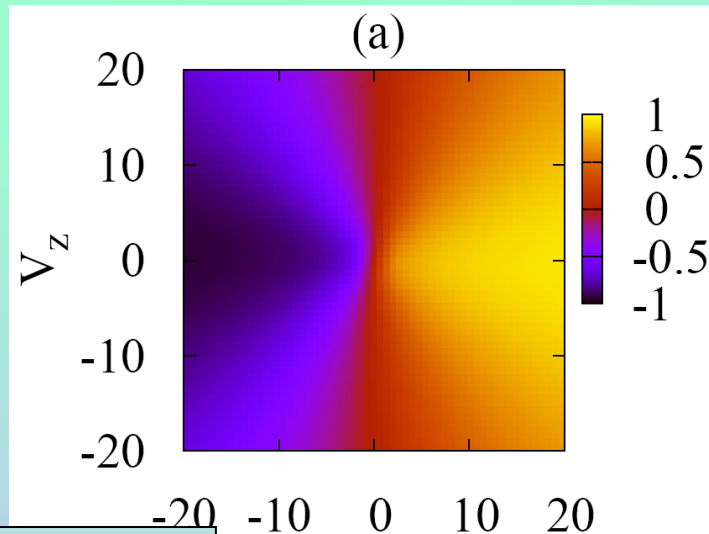

~~Pumping with a strobe: idea~~

- Orientation in x direction: bad
- Bad=rotation about x axis
- To compensate: Measure at the rot. frequency(strobe)
- Does not help pumping...
- Saves number of detectors!
 - was: three detectors=three variables
 - now: two detectors=two variables

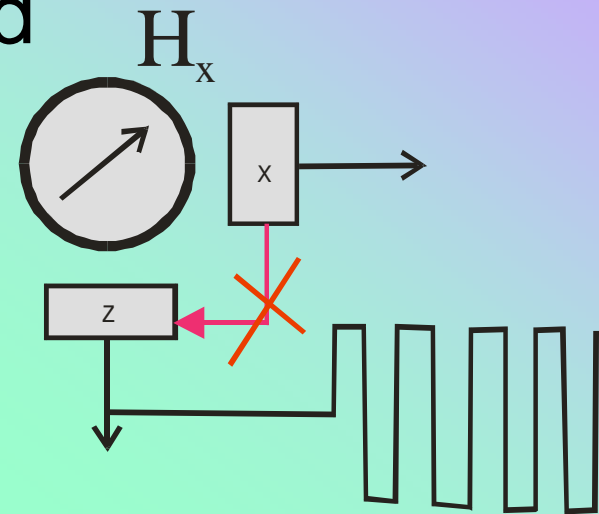

Detector with a strobe: results

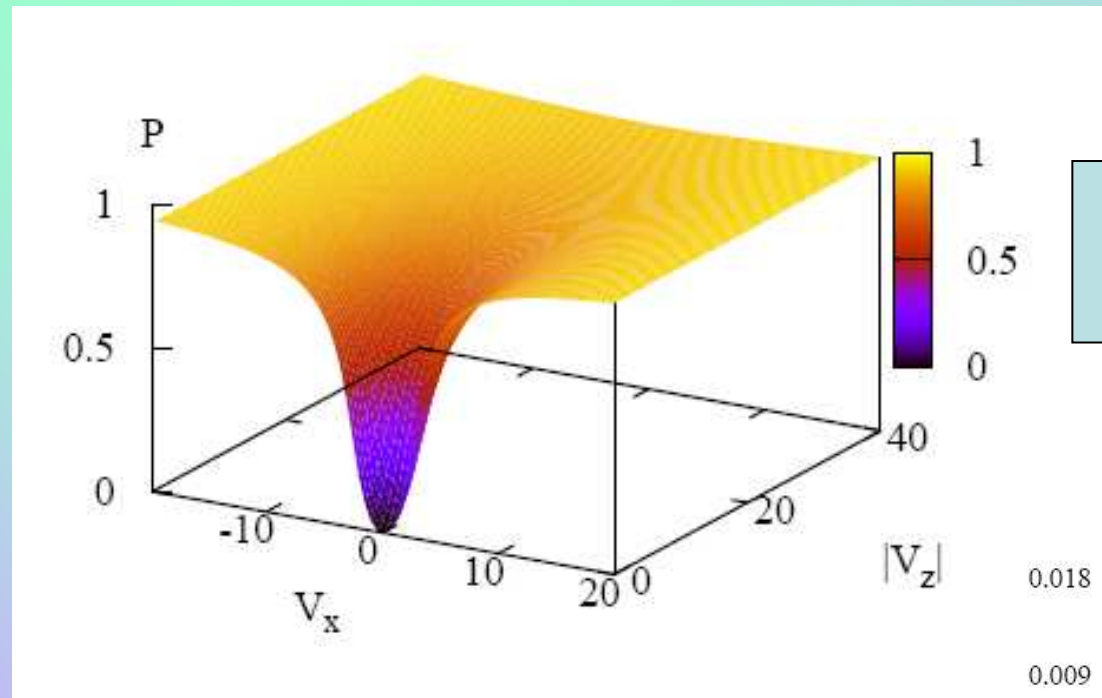

Color: fidelity

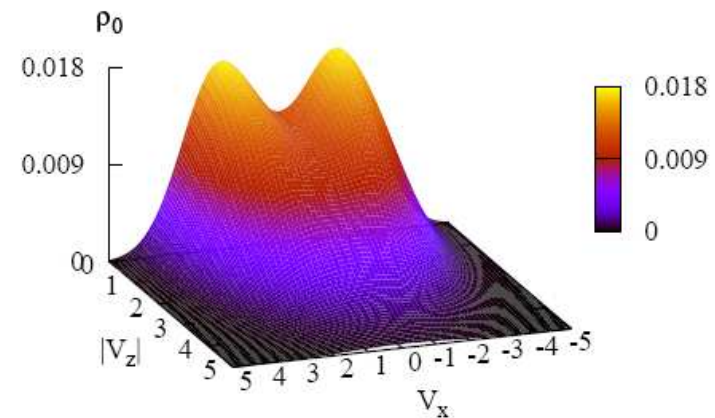

Future

- Clear up (some theory)
- Feedback? Feedback!
 - one qubit: monitoring=purification
 - two qubits: entanglement distillation
 - Entanglement at large distances
 - Checked with statistics
- Back to reality
 - feedback with delay